

89-18-04-230-612.000-030

TURNER, CATHERINE ANDERS

410 S 18TH ST

510, 1 Family Dwell - Platted Lot

WAYNE-293370 (029)/2933

1/2

General Information

Parcel Number 89-18-04-230-612.000-030
Local Parcel Number 50-04-230-612.000-29

Tax ID: 029-45474-00

Routing Number 5004230-033

Property Class 510
1 Family Dwell - Platted Lot

Year: 2025

Location Information

County WAYNE

Township WAYNE TOWNSHIP

District 030 (Local 029)
RICHMOND CITY -WAYNE TWP

School Corp 8385
RICHMOND COMMUNITY

Neighborhood 293370-029
WAYNE-293370 (029)

Section/Plat 5004230

Location Address (1)
410 S 18TH ST
RICHMOND, IN 47374

Zoning

Subdivision

Lot

Market Model
N/A

Characteristics

Topography Level Flood Hazard

Public Utilities All ERA

Streets or Roads Paved TIF

Neighborhood Life Cycle Stage
Static

Printed Tuesday, April 29, 2025

Review Group 2029

Ownership

TURNER, CATHERINE ANDERSON
PO BOX 175
RICHMOND, IN 47375

Legal

LOT 58 REEVESTON



Transfer of Ownership

Date 01/01/1900 Owner TURNER, CATHERIN Doc ID Code Book/Page Adj Sale Price V/I

Notes

8/7/2024 CYCLICAL: 2025 GENERAL REVAL

Valuation Records (Work In Progress values are not certified values and are subject to change)

Table with columns for Assessment Year (2025-2022), Reason For Change, As Of Date, Valuation Method, Equalization Factor, Notice Required, and Land/Improvement/Total values.

Land Data (Standard Depth: Res 132', CI 132' Base Lot: Res 100' X 132', CI 100' X 132')

Table with columns for Land Type, Pricing Method, Soil ID, Act Front, Size, Factor, Rate, Adj. Rate, Ext. Value, Infl. %, Market Factor, Cap 1, Cap 2, Cap 3, and Value.

Land Computations

Table listing various land computations such as Calculated Acreage, Actual Frontage, Developer Discount, Parcel Acreage, and Total Value (\$33,200).

General Information

Occupancy Single-Family
Description Residential Dwelling
Story Height 1 3/4
Style N/A
Finished Area 1592 sqft
Make

Floor Finish

Earth Tile
 Slab Carpet
 Sub & Joist Unfinished
 Wood Other
 Parquet

Wall Finish

Plaster/Drywall Unfinished
 Paneling Other
 Fiberboard

Roofing

Built-Up Metal Asphalt Slate Tile
 Wood Shingle Other

Exterior Features

Description	Area	Value
Patio, Flagstone	102	\$1,900
Patio, Concrete	160	\$1,200
Porch, Open Frame	160	\$8,300
Patio, Brick	87	\$1,400

Plumbing

	#	TF
Full Bath	1	3
Half Bath	1	2
Kitchen Sinks	1	1
Water Heaters	1	1
Add Fixtures	0	0
Total	4	7

Accommodations

Bedrooms	3
Living Rooms	1
Dining Rooms	1
Family Rooms	1
Total Rooms	8

Heat Type

Central Warm Air

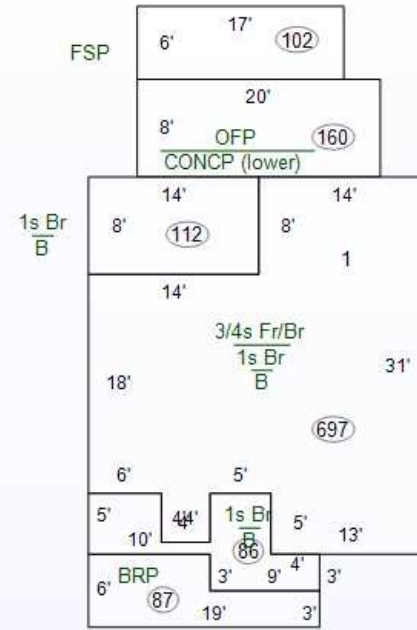

Specialty Plumbing

Description	Count	Value
-------------	-------	-------

Cost Ladder

Floor	Constr	Base	Finish	Value	Totals
1	7	895	895	\$106,900	
2					
3					
4					
1/4					
1/2					
3/4	93	697	697	\$38,100	
Attic					
Bsmt		895	0	\$32,600	
Crawl					
Slab					

Total Base \$177,600

Adjustments 1 Row Type Adj. x 1.00 \$177,600

Unfin Int (-)	\$0
Ex Liv Units (+)	\$0
Rec Room (+)	\$0
Loft (+)	\$0
Fireplace (+)	MS:1 MO:1 \$4,500
No Heating (-)	\$0
A/C (+)	1:895 3/4:697 \$5,300
No Elec (-)	\$0
Plumbing (+ / -)	7 - 5 = 2 x \$800 \$1,600
Spec Plumb (+)	\$0
Elevator (+)	\$0

Sub-Total, One Unit \$189,000

Sub-Total, 1 Units

Exterior Features (+)	\$12,800	\$201,800
Garages (+) 0 sqft	\$0	\$201,800
Quality and Design Factor (Grade)	1.30	
Location Multiplier	0.85	

Replacement Cost \$222,989

Summary of Improvements

Description	Story Height	Constr Type	Grade	Year Built	Eff Year	Eff Co Age	nd	Base Rate	LCM	Adj Rate	Size	RCN	Norm Dep	Remain. Value	Abn Obs	PC	Nbhd	Mrkt	Cap 1	Cap 2	Cap 3	Improv Value
1: Residential Dwelling	1 3/4	5/6 Maso	B+1	1937	1955	70	A		0.85		2,487 sqft	\$222,989	38%	\$138,250	0%	100%	1.210	1.000	100.00	0.00	0.00	\$167,300
2: Detached Garage/Boat H	1	Brick	B	1935	1935	90	A	\$65.43	0.85	\$71.80	15'x22'	\$23,693	40%	\$14,220	0%	100%	1.210	1.000	100.00	0.00	0.00	\$17,200